

CT 8800 / FR 8800 / JM 8800
LS 8800 / MB 8800 / MK 8800 / TT 8800
CONCEALED ARCHIPELAGO THERMOSTATIC
SHOWER VALVE
INSTALLATION GUIDE

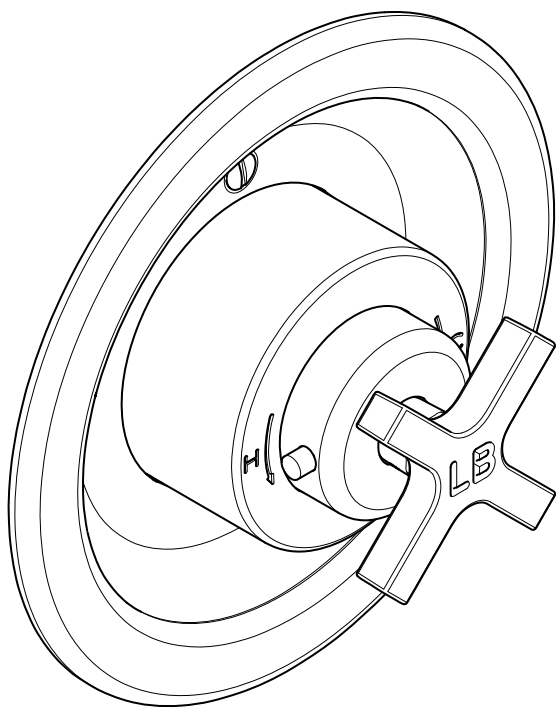

LEFROY BROOKS

DIMENSIONS

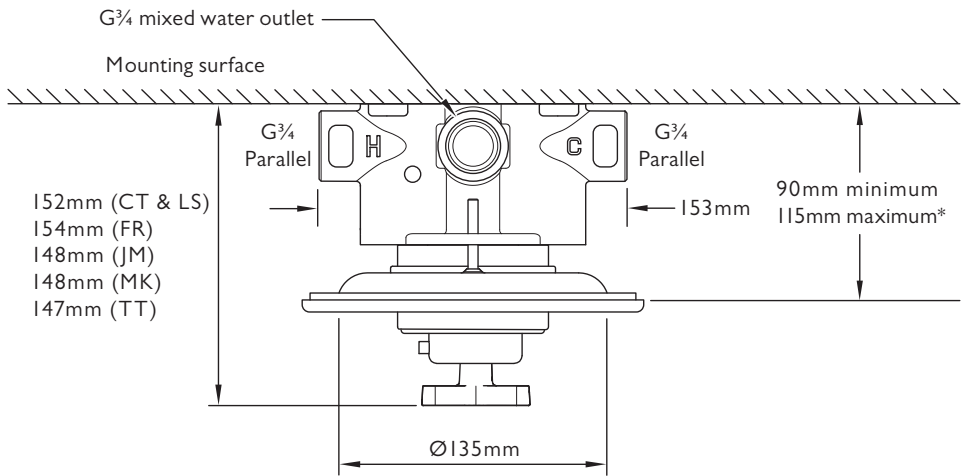
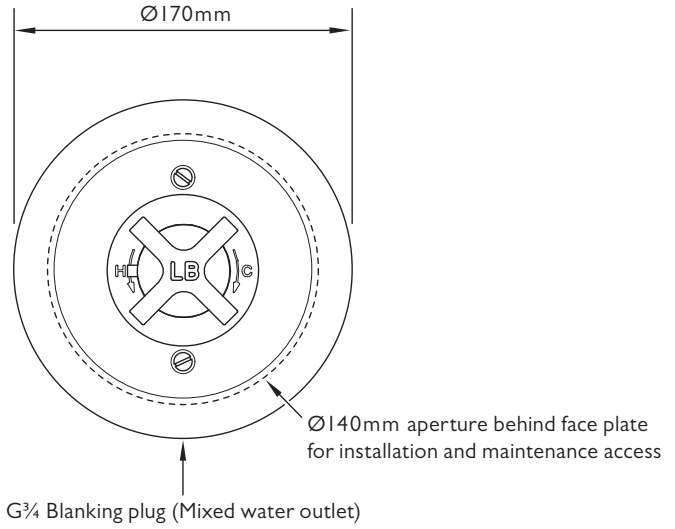

TOP VIEW

Not to scale

*Please note: 25mm extension kits are available (Part number MK8898)

EXPLODED VIEW

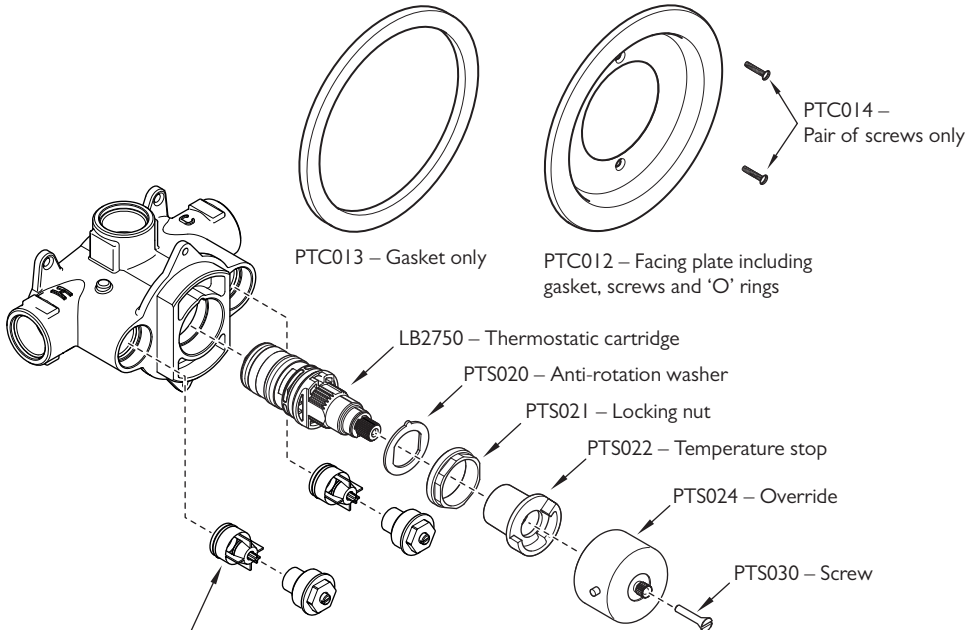

PTS011 –
(CT) Ceramic ring only

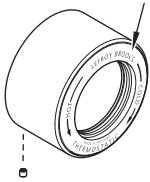

PTC020 – (CT)
Thermostatic
cartridge cover

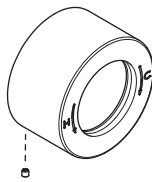

PTC024 –
(JM MB MK TT)
Thermostatic
cartridge cover

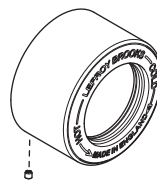

PTC023 –
(LS) Thermostatic
cartridge cover
including set screw

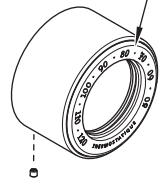

PTC055 – (FR)
Thermostatic
cartridge cover

PTS034 –
(FR) Ceramic ring only

PTS010 – (CT)
Lion indice only



PTS026 –
(CT) Cross handle
with lion indice
including set screw



PTS025 –
(JM MB MK)
Cross handle
including set screw



PTS028 –
(FR) Cross handle
including set screw



PTS033 –
(TT) Handwheel
including set screw



PTS032 –
(LS) Handwheel
including set screw

TYPICAL LAYOUT

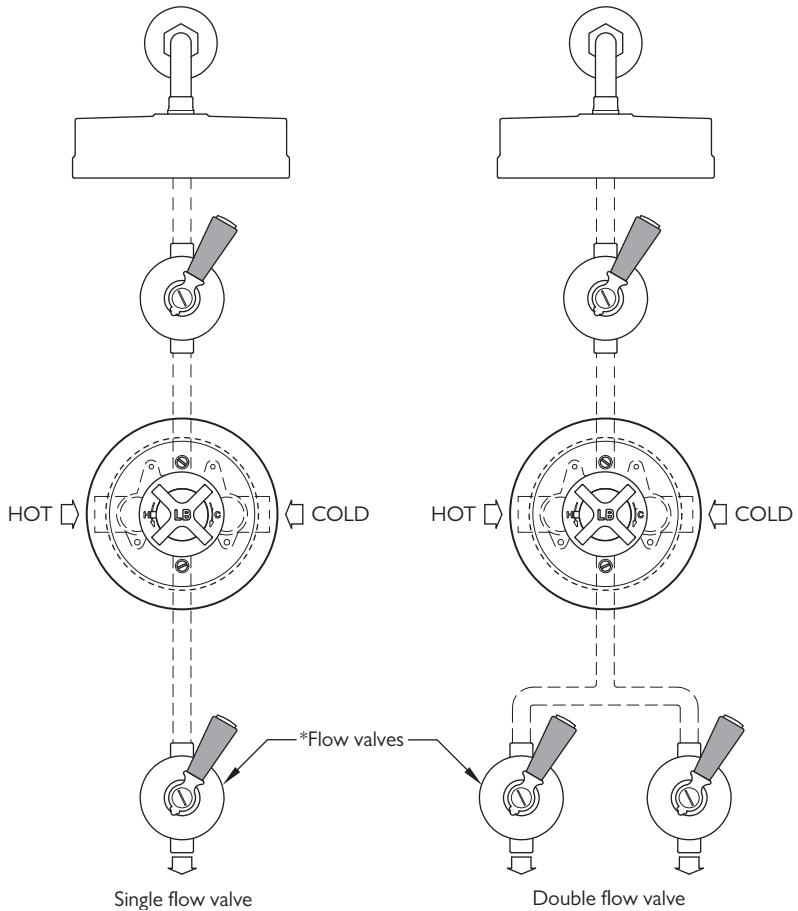

For adding a hand shower, body jets or bath filler, remove the $\frac{3}{4}$ " BSP plug from the bottom of the valve body and connect suitable flow valve(s).

*Flow valves are available as 'CH' (Connaught cross handle), 'FH' (La Chapelle cross handle), 'LS' (Classic Star handle), 'ML' (Mackintosh all metal lever), 'MB' (Mackintosh black lever), 'MH' (Mackintosh cross handle), 'MK' (Mackintosh black ceramic lever), 'JL' (Janey Mac lever), 'JH' (Janey Mac cross handle), 'TH' (Ten Ten handwheel) & 'TL' (Ten Ten lever).
(Refer to flow valve installation instructions)

TYPICAL FLOW RATES

The flow rate indicated is for one outlet only.

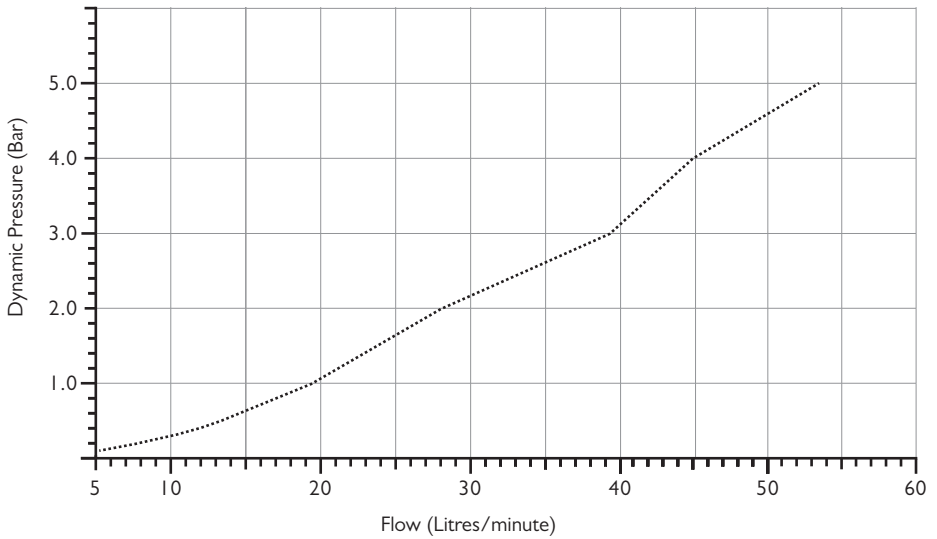

Note: Balanced pressures shown are applied directly to the hot and cold inlets; flow rates indicated are free flowing and may vary subject to restrictions created by installation, pipework, layout or application. Upper and lower outlets have the same flow rates. The outlet temperature during testing was 38°C.

IMPORTANT INFORMATION

Professional installation

We recommend that our products are fitted by a fully qualified professional plumber. They should be installed correctly and in accordance with all local water regulations. All products and connections should be accessible for routine servicing.

Suits all systems

This Lefroy Brooks product is potentially suitable for every possible application, type of boiler and water supply pressure. However, for full 'power' shower performance it is advisable to fit a water pump if the supply pressure is below 1 bar. For systems with combination boilers, it is not advisable to fit pumps (refer to boiler manufacturer).

Recommended supply temperatures

HOT = 55/60°C

COLD = 10/15°C

Water quality

In hard water areas, a suitable water treatment system should be provided to prevent limescale deposits (calcium deposits) which may effect the long term performance of the thermostatic cartridge. Exterior surfaces should be gently wiped with a dry soft cloth after use to minimise water stains and limescale deposits.

Servicing

All serviceable parts are available to maintain your Lefroy Brooks product. We recommend periodic servicing to help maintain the best performance from your shower ('Servicing the thermostatic cartridge' & 'Replacing the non-return valve' sections). Time between servicing can vary as it is subject to usage and water quality.

Flushing system

It is most important to flush out all pipework thoroughly before connecting the product. Failure to do so is the single most common cause of ceramic cartridge and thermostatic cartridge failure.

Supply connections

The hot water supply must be connected to the left port and cold water to the right port as viewed from the front.

Balancing flow

If there is a significant difference in water pressures between hot & cold supplies, we recommend an in-line flow suppressor/regulator (not supplied) be fitted. This should be fitted to whichever has the greater flow rate, in an accessible position close to the valve.

Safety/Anti-scald

This thermostatic valve not only maintains a constant temperature to approximately plus or minus 1°C, but will automatically shut down completely on failure of hot or cold supplies.

Temperature setting

Once the installation has been completed the 'safe temperature' must be checked and set in accordance with the setting instructions (see following 'Setting safe temperature' & 'Fitting the temperature override' sections). The valve is factory set but the working temperature may differ subject to the hot & cold water temperatures being supplied to the valve.

Making connections

Parallel fittings (direct to valve)

Direct connections to the valve inlets and outlets should only be made using $\frac{3}{4}$ " BSP parallel fittings (refer to 'typical layout' section).

Tapered fittings (use adapters)

Tapered adapters are available to convert the connections and enable tapered fittings to be used ($\frac{3}{4}$ " BSP – PTC027). These should be securely fitted to the valve using a suitable thread sealing compound to make a watertight joint.

Tapered fittings must NOT be connected directly to the valve without the use of adapters.

Fixing valve to wall

Secure the valve to the wall using suitable screws and wall plugs (supplied). All connections should be pressure tested before the valve is sealed behind the wall.

Non-return valves

To protect your water system, non-return valves are fitted behind the face plate and are accessible from the front. These can be removed and cleaned if required.

Testing

Before the valve is sealed behind the finished wall surface it is important to pressure check all connections. During manufacture the internal components of the valve are pressure tested to 5 bar. However, installation can affect the external joints. For this reason we recommend that all connections to and from the valve are pressure tested. We also recommend that the blanking plug at the bottom of the valve is checked.

Access

It is important to leave suitable clearance and access to the valve and connections for future servicing.

Setting the 'safe temperature'

To avoid damage, when setting the 'safe temperature' the thermostatic cartridge spindle must be turned by hand only. The spindle will require only minor adjustment. **Turning the spindle to the end of its travel and forcing it beyond this point will cause internal damage to the thermostatic cartridge.**

Always fit the black plastic 'temperature stop' before fitting the 'override'. One of the functions of the temperature stop is to prevent the thermostatic cartridge spindle being turned beyond the end of its travel. **Not fitting the temperature stop will result in damage to the thermostatic cartridge.**

SETTING 'SAFE TEMPERATURE'

The recommended safe temperature settings is 38 °C

For specific details please refer to local building regulations, current legislation, relevant standards and codes of practice.

This valve is designed to be set at the required safe operating temperature, but is fitted with an override button which allows the user to select higher temperatures if required. The override control is to be returned to the 'safe temperature' setting after use.

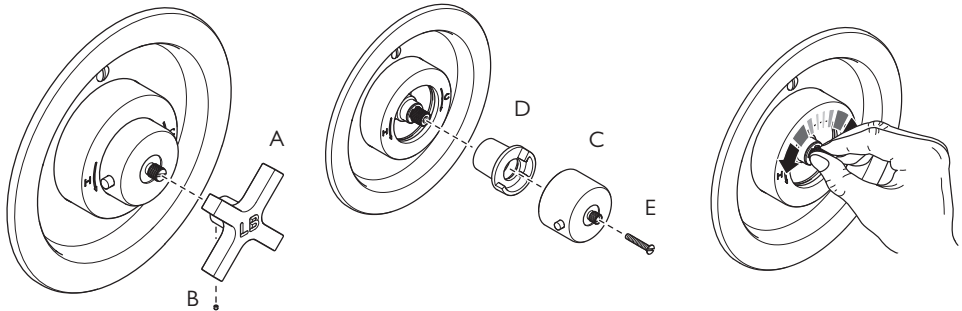

Remove the thermostatic control cross handle/ handwheel (A) by unscrewing set screw (B) using a 1.5mm hexagonal key.

Remove the override (C) and temperature stop (D) by unscrewing and removing screw (E). Fitting cross handle/ handwheel (A) and set screw (B) will aid with removal of override (C).

Adjust the cartridge spline whilst measuring the temperature of the water. Ideally the temperature measurement should be taken using a digital thermometer.

Duty of care

Legislation dictates recommendations and guidelines on health and safety, including safe hot water temperatures. The emphasis is on regulatory and design criteria, with responsibility for meeting such guidelines being that of a suitably appointed responsible person.

How hot water temperatures affect the skin

- 65°C A partial thickness burn in about 2 seconds
- 60°C A partial thickness burn in about 5 seconds
- 55°C A partial thickness burn in about 15 seconds
- 50°C A partial thickness burn in about 90 seconds

Safe temperature

The age, mental and physical capabilities of persons occupying the property will effect the 'safe temperature' setting of the thermostatic valve. For specific details please refer to local building regulations, current legislation, relevant standards and codes of practice.

FITTING THE 'TEMPERATURE OVERRIDE'

Once the safe operating temperature has been set, the next stage is to correctly assemble the temperature stop (D) & override (C). The temperature stop and 'safe temperature' button can be positioned to customer requirements. The below setting is suitable for right handed operation.

Three typical settings are shown on the next page.

Temperature stop (D) orientation

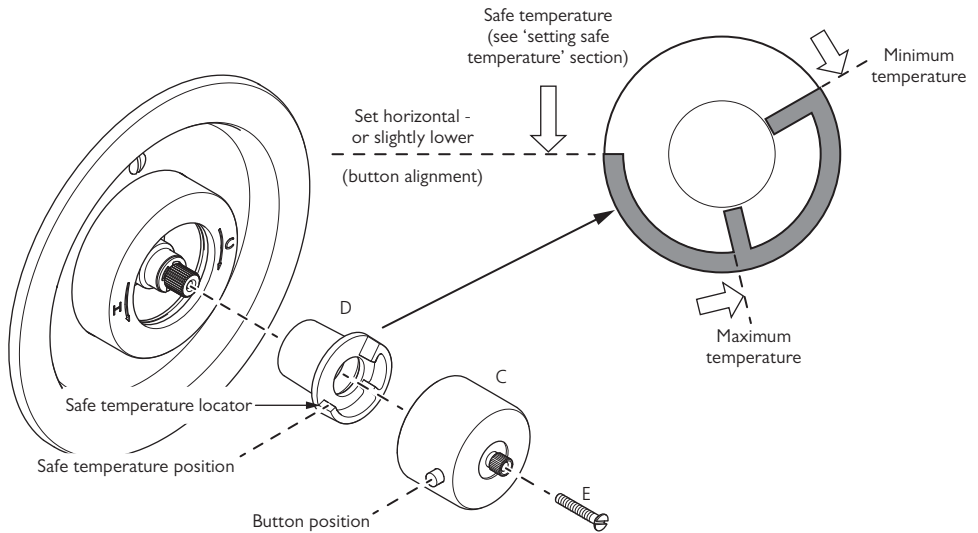

- 1 Locate the temperature stop (D) onto the cartridge spline with the 'safe temperature' locator in a horizontal or slightly lower position. This is dependent on the orientation of the splines (as shown above). Do not set higher as this will effect the position of the button on the override (C). Once located in a suitable position push the temperature stop in fully.
- 2 Locate the override (C) with the button positioned horizontally and to the left. Slide the override carefully onto the smaller cartridge spline. There may be a small amount of rotation required to align the override mechanism with the safe temperature position.
Note: The button may not be perfectly horizontal depending on the orientation of the cartridge splines.
- 3 Secure with screw (E). It is important to check the water temperature.
- 4 Fit the temperature control cross handle/handwheel (A) ensuring the button is aligned between the arms of the cross handle/handwheel, tighten set screw (B) using a 1.5mm hexagonal key to secure.

The temperature stop and safe temperature button can be positioned to customer requirements as below:

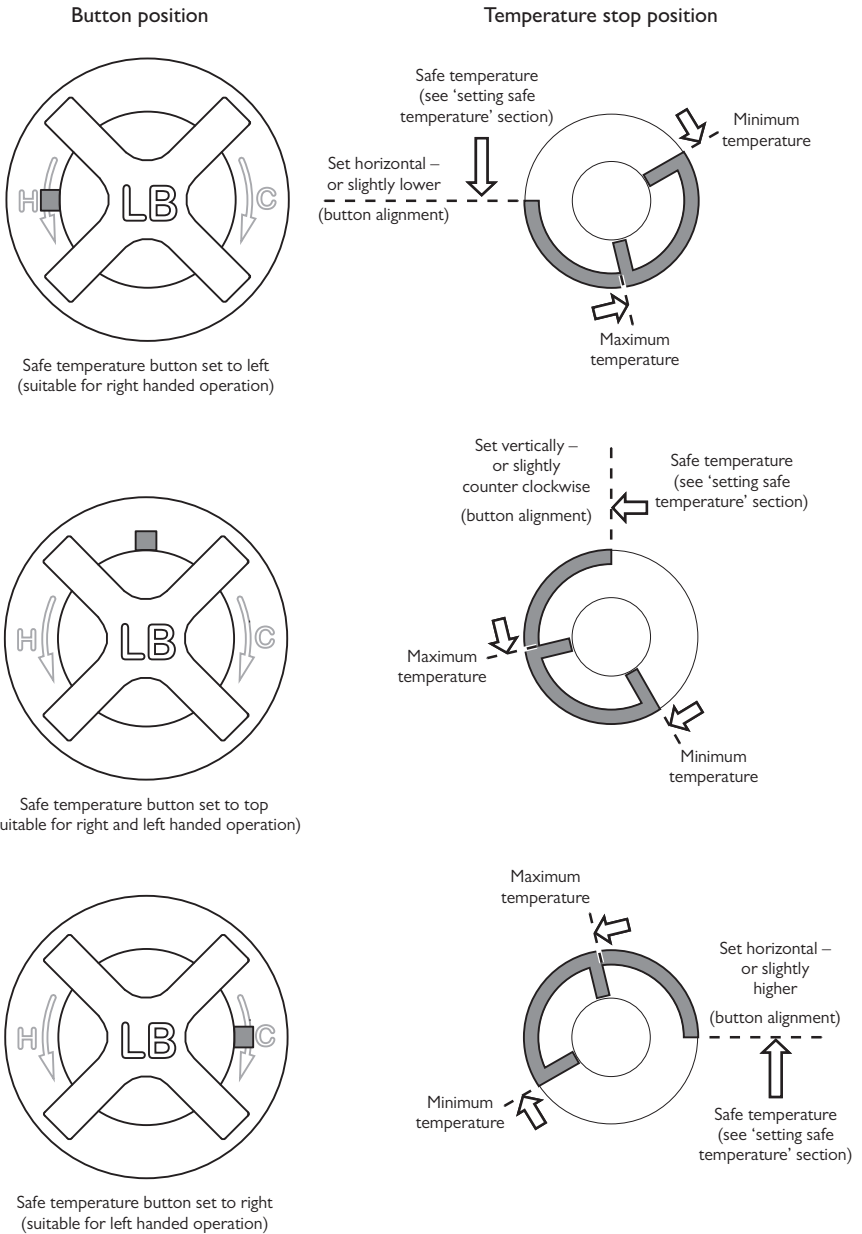

SERVICING THE THERMOSTATIC CARTRIDGE

If after a period of time you experience temperature problems with your shower valve, particularly if you are in a hard water area, it is quite common for limescale deposits to have formed in the thermostatic cartridge. We recommend you remove the cartridge and soak it in a descaling fluid which normally resolves the problem. It is difficult to set a regular servicing time scale as it is subject to water conditions and usage.

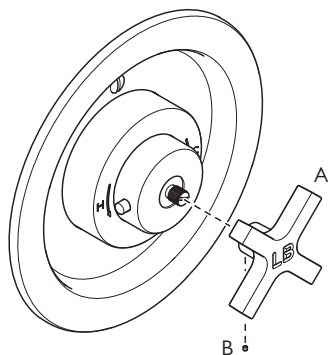

- 1 Using a 1.5mm hexagonal key, unscrew set screw (B) from the thermostatic control handle (A). Remove the handle.

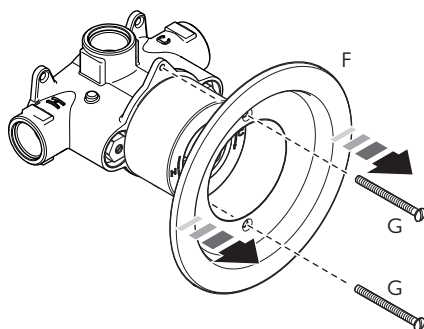

- 3 To remove the facing plate (F) unscrew and remove fully the two fixing screws (G). Carefully prise the facing plate off the wall (the gasket is reusable).

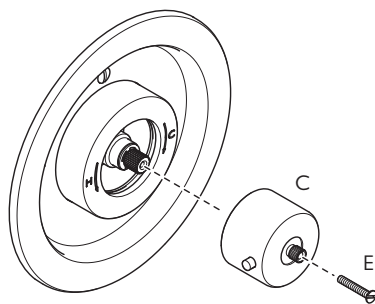

- 2 Remove the override (C) by unscrewing and removing screw (E).

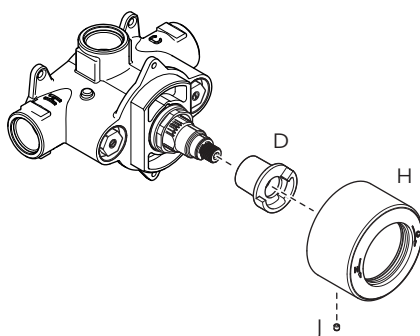

- 4 Remove the thermostatic cartridge cover (H) by unscrewing set screw (J) using a 1.5mm hexagonal key. Temperature stop (D) can be pulled off.

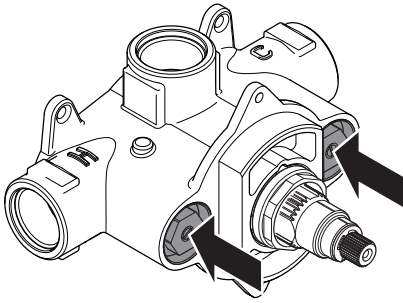

- 5 Isolate the hot and cold water supplies as follows: The non-return valve carriers have a screw in the centre. Use a screwdriver to turn the screws in a clockwise direction until they reach their stop. Do not over tighten the screws as this may damage the non-return valves.

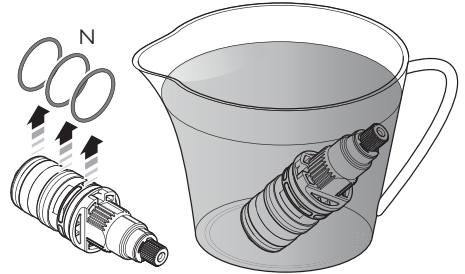

- 7 Check the 'O' rings (N) for damage (ie. cuts or tears). Remove the 'O' rings before soaking the cartridge in descaling fluid. Soak the cartridge according to the instructions on the descaling fluid packaging. Rinse under cold water before fitting (refer to the 'installing the thermostatic cartridge' section to install).

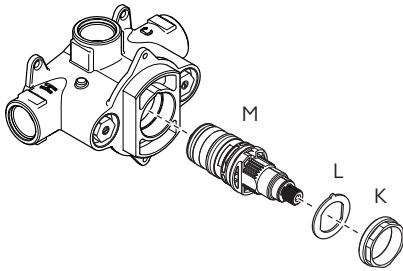

- 6 To remove the thermostatic cartridge, unscrew and remove locking nut (K). Remove anti-rotation washer (L) and pull out cartridge (M). To help with cartridge removal, it is recommended you fit override (C) with screw (E) to make pulling the cartridge out easier.

INSTALLING THERMOSTATIC CARTRIDGE

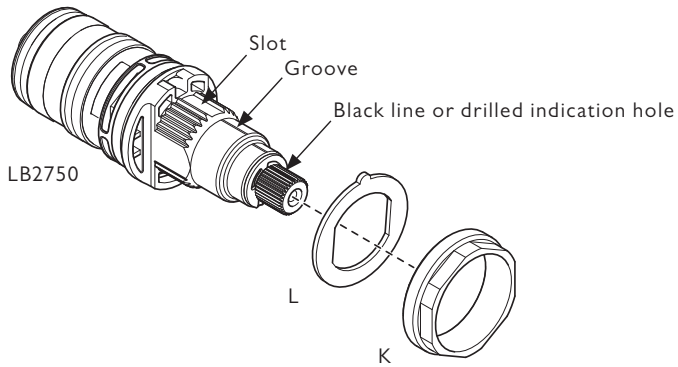

Important note:

For an approximately 38°C setting, align the 'key setting points' shown. Once assembled, reset the safe temperature by following the setting instruction in the 'setting safe temperature' section. Check the water temperature with a thermometer.

1 Once the 'key setting points' have been aligned and 'O' rings (N) fitted, apply a smear of silicon grease to the 'O' rings and firmly push the thermostatic cartridge (LB2750) into the valve body with the groove pointing upwards.

- 2 Insert the anti-rotation washer (L) so it locates to the 'flats' on the cartridge and fits into the 'notch' cut into the valve body.
- 3 Screw in locking nut (K) and fully tighten using a 32mm a/f spanner to secure the thermostatic cartridge in place.

REPLACING THE NON-RETURN VALVES

Begin by following steps 1 to 4 in the 'Servicing the thermostatic cartridge' section.

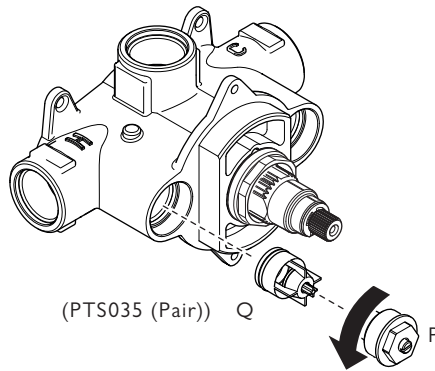

- 1 Isolate the hot and cold water supplies before the shower valve. With the cross handle/ handwheel, override, temperature stop and cartridge cover removed, you can see the non-return valve cover(s). Using a 17mm spanner or socket, unscrew and remove the non-return valve cover(s) (P). Non-return valves are sold as pairs. The code for these is PTS035.

- 2 Remove the non-return valve (Q) with the use of long nose pliers or a similar tool.
- 3 Before installing the replacement non-return valve(s) apply a small amount of silicone grease to the rubber 'O' ring. Assemble in reverse order.

DOs

- Check all joints and connections before sealing the valve behind the finished wall/mounting surface.
- Ensure that the 'safe temperature' has been set.
- Ensure the black plastic 'temperature stop' has been fitted to avoid damage to the thermostatic cartridge and enable the 'safe temperature' to be operational.
- Ensure that the thermostatic valve, connected controls and outlets work satisfactory.
- Instruct the customer how to override the 'safe temperature' setting. Also ensure the customer knows the dangers of overriding the setting and understands that the override control is to be returned to the 'safe temperature' setting after use.
- Hand these instructions along with the cleaning leaflet to the customer.
- Ensure that the valve is suitably protected from damage and decorating materials during installation.

DON'Ts

- Do not use excessive force when turning the thermostatic cartridge spindle. This will damage the cartridge. To avoid damage, when setting the 'safe temperature' the thermostatic cartridge spindle must be turned by hand only. The spindle will require only minor adjustment. **Turning the spindle to the end of its travel and forcing it beyond this point will cause internal damage to the thermostatic cartridge.**



CONTRACT ENQUIRIES
+44 (0)1992 708 316

info@lefroybrooks.co.uk

CUSTOMER SERVICE, SPARES & TECHNICAL ENQUIRIES

+44 (0)1902 390 894

technical@lefroybrooks.co.uk

LEFROYBROOKS.CO.UK

Whilst every effort is made to ensure the accuracy of these, they are subject to change without notice as part of the company's product development process. The use of trademarks, product design and artwork is subject to licence or agreement with LBIP Ltd. The design registrations, trademark registrations and copyrights are protected by law and the use or reproduction outside the terms of an agreement is prohibited. The right to modify designs and dimensions is reserved. LBIP Ltd is a member of ACID (Anti Copying in Design). E&OE